

REV.	REVISION HISTORY	DATE
0	FIRST PRODUCTION RELEASE	20/11/2007
1	CHANGED TO CN HINGE CL-230-2	07/04/2008
2	CHANGED REAR KEYHOLE CUTOUTS	
3	UPDATED HORIZONTAL AND VERTICAL RAILS	05/12/2009
4	ADDED CUTOUS FOR SECOND FAN	14/12/2009

Item Number	Document Number	Revision	Title	Quantity
1	12-600-001	4	BODY HALF 12RU 600 DEEP	2
2	12-DR-007	3	DOOR PERPEX ASSEMBLY 12RU	1
3	12-VR-002	1	12RU VERTICAL RAIL	4
4	600-HR-003	2	HORIZONTAL RAIL 600 DEEP	4
5*	M6 DOME NUT	----	M6 DOME NUT	2
6*	M6 FLAT WASHER - ZP	----	M6 FLAT WASHER - ZP	2

ADDITIONAL FASTENERS AND HARDWARE REQUIRED FOR COMPLETION
 2 OFF DOOR HINGES PT.NO. EMKA- 1110-U3 (OR CL-230-2)
 4 OFF M5 SERRATED FLANGE HEX NUTS (HINGE TO DOOR)&(ROD MOUNT BKTS TO CABINET)
 2 OFF M5 X 10 HEX SCREW (HINGE TO CABINET)
 4 OFF M6 X 14 THUMB SCREW BLACK AND INTERNAL SHAKEPROOF WASHER (V.RAILS TO H. RAILS)

ASSEMBLY PROCEDURE -
 SPOTWELD HORIZONTAL RAILS TO BODY HALVES.
 TIGWELD BODY HALVES TOGETHER ON INNER CORNERS ONLY.
 CHECK SIZE 600mm OVERALL MINIMUM GAPS IN CORNERS
 SPOTWELD BODY HALVES TOGETHER, THEN FUSION WELD OUTER CORNERS.
 MASK THREADS
 POWDERCOAT BODY, THEN FIT V.RAILS AND DOOR

NOTE: ALL DIMENSIONS EXTERNAL UNLESS NOTED OTHERWISE

DRAWN BY:	INITIAL	TOLERANCES TOLERANCES SET BY NUMBER OF DECIMAL PLACES. ie: 1 decimal - 0.0 = +/- 0.5mm 2 decimals-0.00 = +/- 0.15mm ANGLES +/- 0.5 deg. ○ DENOTES CRITICAL DIMENSION	MATERIAL	FINISH POWDERCOAT GREY NURSE RIPPLE
	CHECKED BY:		INITIAL	PROJECT WALL MOUNT CABINET
FLAT PATTERN DISCLAIMER AS INDIVIDUAL MANUFACTURERS TOOLING MAY VARY WIDELY IT IS THE MANUFACTURERS RESPONSABILITY TO DETERMINE CORRECT FLAT SIZES OR WHETHER THE SUPPLIED FLAT DIMENSIONS ARE ACCURATE		SHEET 1 OF 2 AS 1100	DRAWING NO. 12-600-000	FILENAME: 12-600-000.asm
TITLE GENERAL ASSY. 12RUX 600 CABINET			REV. 4	DATE 11/02/2014

REV.	REVISION HISTORY	DATE
0	FIRST PRODUCTION RELEASE	20/11/2007
1	CHANGED TO CN HINGE CL-230-2	07/04/2008
2	CHANGED REAR KEYHOLE CUTOUTS	
3	UPDATED HORIZONTAL AND VERTICAL RAILS	05/12/2009
4	ADDED CUTOUS FOR SECOND FAN	14/12/2009

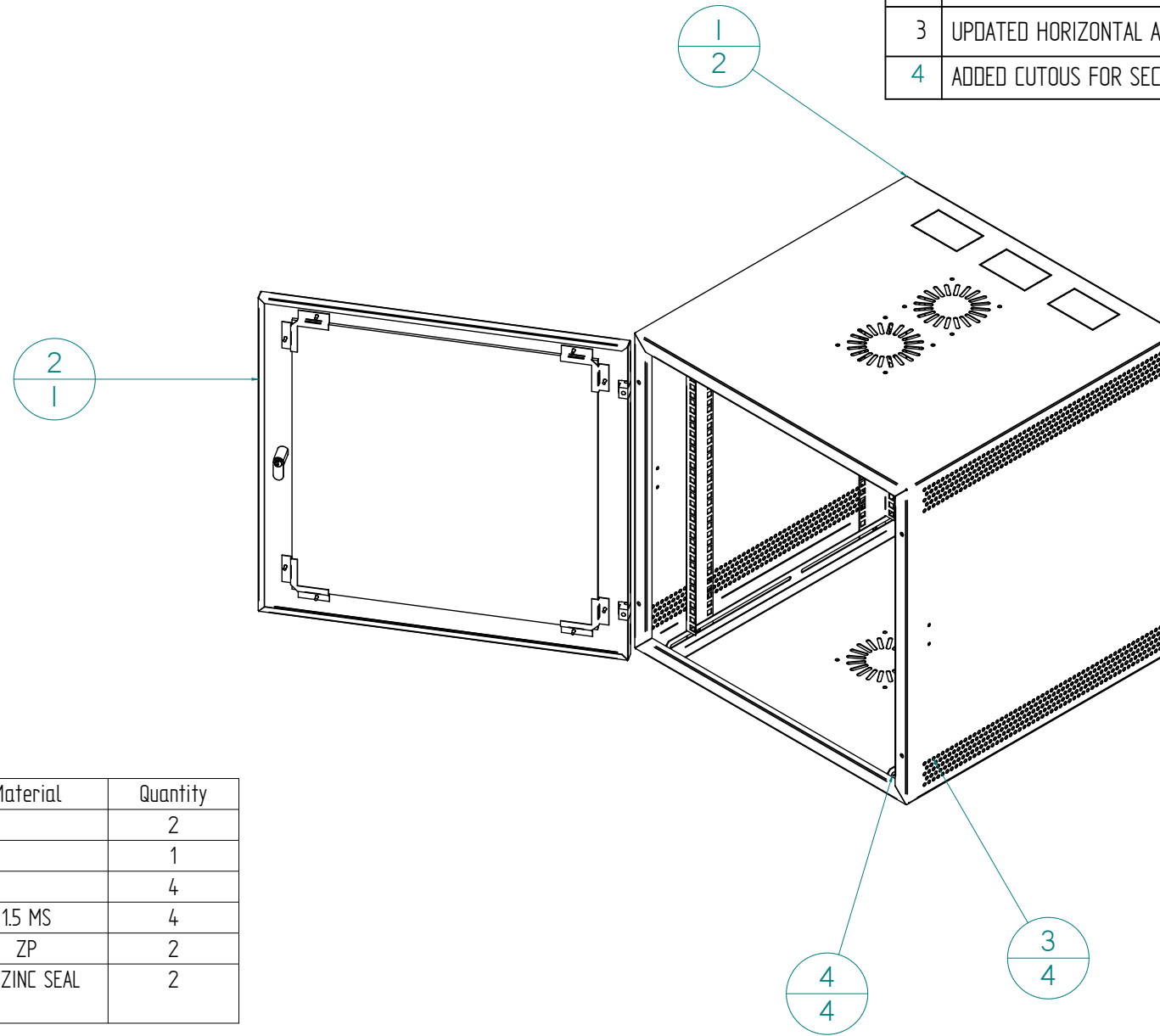

Item	Document Number	Rev.	Title	Material	Quantity
1	12-600-001	4	BODY HALF 12RU 600 DEEP		2
2	12-DR-007	3	DOOR PERPEX ASSEMBLY 12RU		1
3	12-VR-002	1	12RU VERTICAL RAIL		4
4	600-HR-003	2	HORIZONTAL RAIL 600 DEEP	1.5 MS	4
5*	M6 DOME NUT	----	M6 DOME NUT	ZP	2
6*	M6 FLAT WASHER - ZP		M6 FLAT WASHER - ZP	1.2 ZINC SEAL	2

<small>FLAT PATTERN DISCLAIMER</small> AS INDIVIDUAL MANUFACTURERS TOOLING MAY VARY WIDELY IT IS THE MANUFACTURERS RESPONSABILITY TO DETERMINE CORRECT FLAT SIZES OR WHETHER THE SUPPLIED FLAT DIMENSIONS ARE ACCURATE	DRAWN BY: _____ <small>INITIAL</small>	CHECKED BY: _____ <small>INITIAL</small>	TOLERANCES TOLERANCES SET BY NUMBER OF DECIMAL PLACES. ie: 1 decimal - 0.0 = +/- 0.5mm 2 decimals-0.00 = +/- 0.15mm ANGLES +/- 0.5 deg. DENOTES CRITICAL DIMENSION	MATERIAL _____ FINISH POWDERCOAT GREY NUSSANCE RIPPLE	PROJECT WALL MOUNT CABINET	A3
	SHEET 2 OF 2 AS 1100	DRAWING NO. 12-600-000	FILENAME: 12-600-000.asm	TITLE GENERAL ASSY. 12RUX 600 CABINET	REV. 4	DATE 11/02/2014