

REV.	REVISION HISTORY	DATE
0	FIRST PRODUCTION RELEASE	10/03/2014
1	HINGE HOLES CHANGED FOR CN HINGE	
2	KEYHOLE CUTOUTS AND DETAIL "C" ADDED	
3	REVISED REV 2 HOR. RAILS AND REVISED VERT. RAILS- REVISED DOOR WITH PERSPEX CLAMPS	07/12/2009
4	EXTRA HOLES FOR SECOND FAN ADDED	14/12/2009

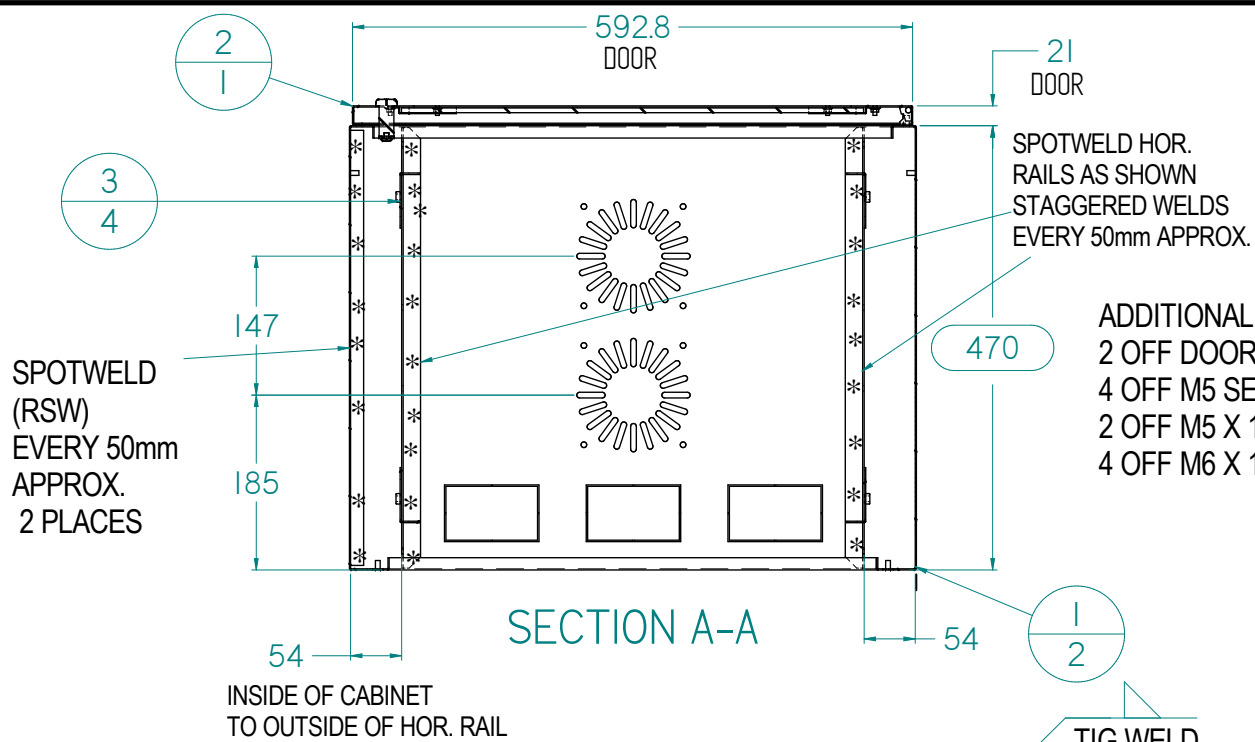

ADDITIONAL FASTENERS AND HARDWARE REQUIRED FOR COMPLETION
 2 OFF DOOR HINGES PT.NO. EMKA- 1110-U3 (OR CL-230-2)
 4 OFF M5 SERRATED FLANGE HEX NUTS (HINGE TO DOOR)&(ROD MOUNT BKTS TO CABINET)
 2 OFF M5 X 10 HEX SCREW (HINGE TO CABINET)
 4 OFF M6 X 14 THUMB SCREW BLACK AND INTERNAL SHAKEPROOF WASHER (V.RAILS TO H. RAILS)

ASSEMBLY PROCEDURE -
 SPOTWELD HORIZONTAL RAILS TO BODY HALVES.
 TIGWELD BODY HALVES TOGETHER ON INNER CORNERS ONLY.
 CHECK SIZE 600mm OVERALL MINIMUM GAPS IN CORNERS
 SPOTWELD BODY HALVES TOGETHER, THEN FUSION WELD OUTER CORNERS.
 MASK THREADS
 POWDERCOAT BODY, THEN FIT V.RAILS AND DOOR

Item Number	Document Number	Revision	Title	Quantity
1	18-470-001	4	1/2 Box Body 18 RU X 470	2
2	18-DR-007	2	DOOR ASSEMBLY 18RU WALL MOUNT	1
3	18-VR-002	2	18RU VERTICAL RAIL SUB ASSEMBLY	4
4*	470-HR-003	2	HORIZONTAL RAIL 470 DEEP	4

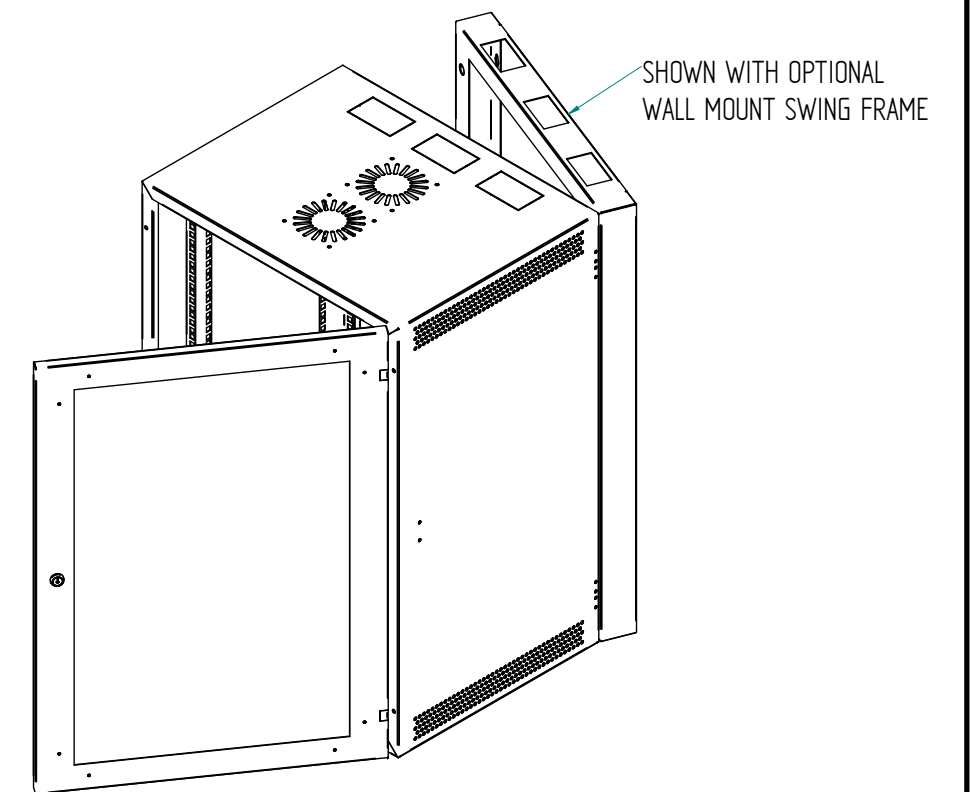
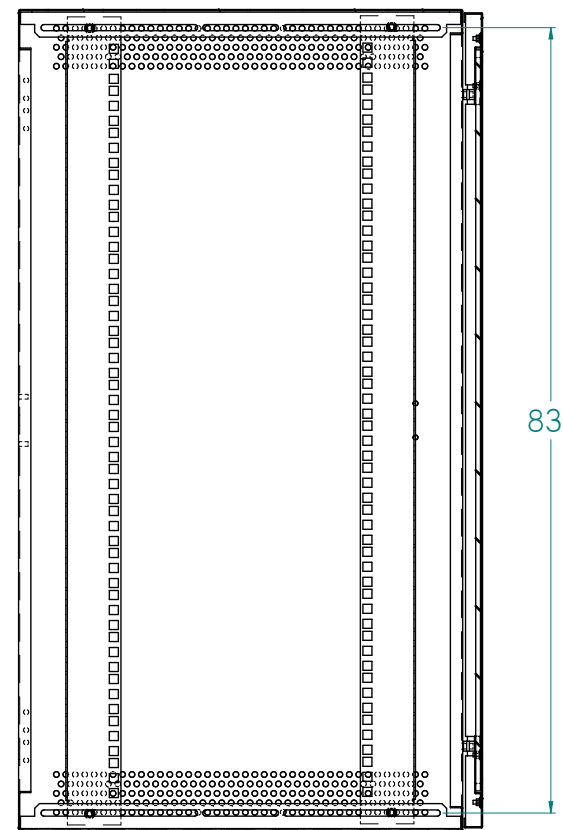
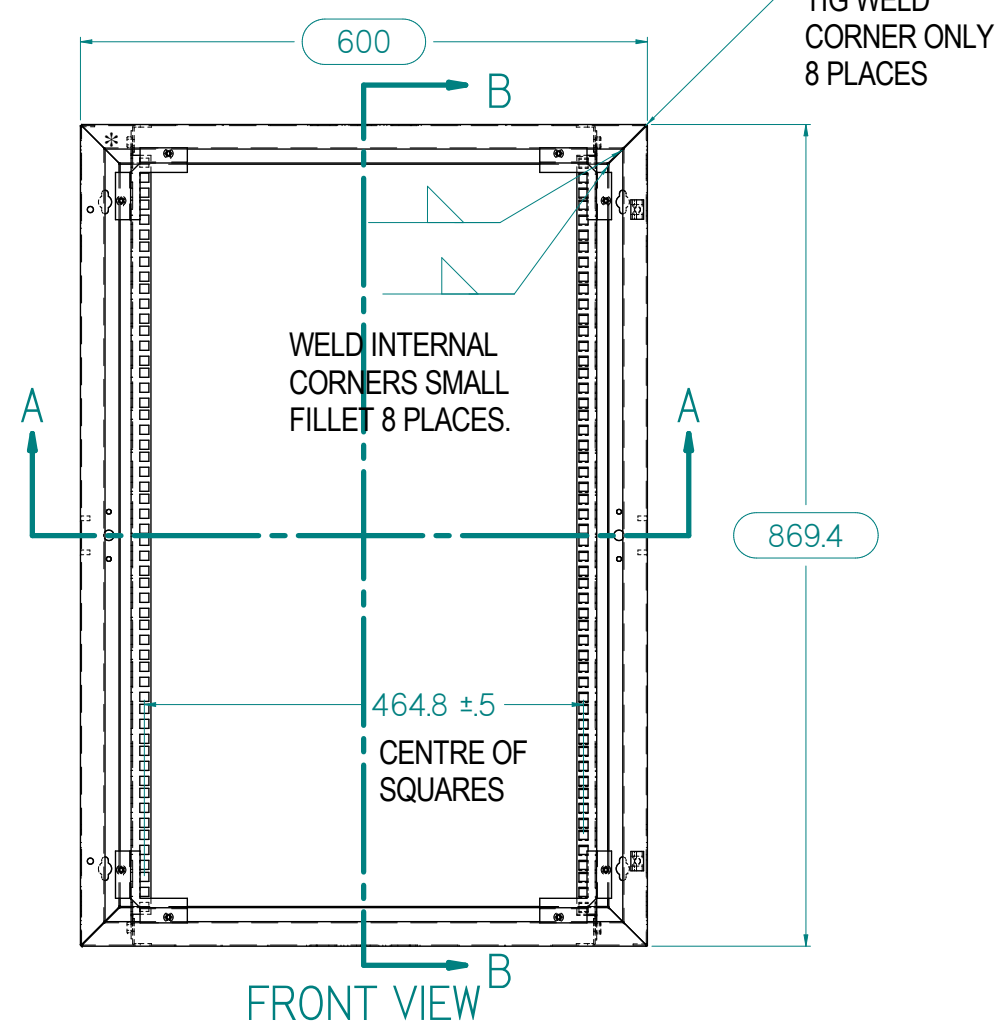

NOTE: ALL DIMENSIONS EXTERNAL UNLESS NOTED OTHERWISE

DRAWN BY:	INITIAL	TOLERANCES TOLERANCES SET BY NUMBER OF DECIMAL PLACES. ie: 1 decimal - 0.0 = +/- 0.5mm 2 decimals-0.00 = +/- 0.15mm ANGLES +/- 0.5 deg. ○ DENOTES CRITICAL DIMENSION	MATERIAL	FINISH
	CHECKED BY:		INITIAL	PROJECT WALL MOUNT CABINET
FLAT PATTERN DISCLAIMER AS INDIVIDUAL MANUFACTURERS TOOLING MAY VARY WIDELY IT IS THE MANUFACTURERS RESPONSIBILITY TO DETERMINE CORRECT FLAT SIZES OR WHETHER THE SUPPLIED FLAT DIMENSIONS ARE ACCURATE		SHEET 1 OF 1 AS 1100	DRAWING NO. 18-470-000	FILENAME: 18-470-000.asm
THIS DRAWING AND ALL INFORMATION AND DESIGNS WITHIN ARE THE PROPERTY OF C.R.S. THE USE OF THE DESIGNS, COPYING IN WHOLE OR PART IS FORBIDDEN WITHOUT THE WRITTEN PERMISSION OF C.R.S. COPYRIGHTS RESERVED.			TITLE GENERAL ASSY.18RU CABINET	REV. 4 DATE 8/09/2014