

TOP VIEW

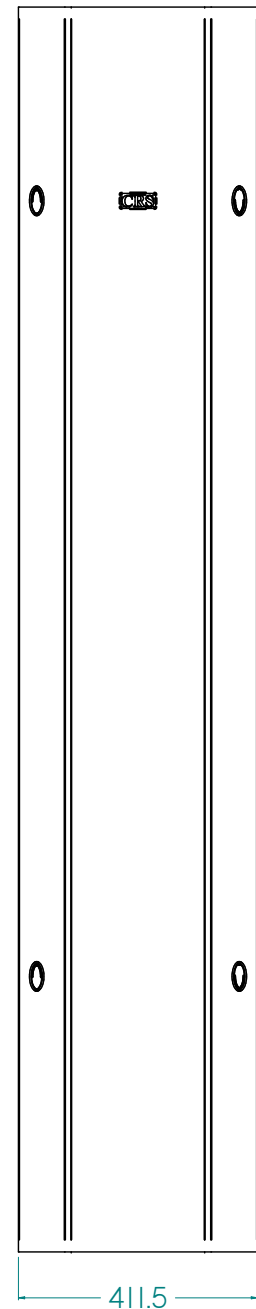

FRONT VIEW  
1:1.3

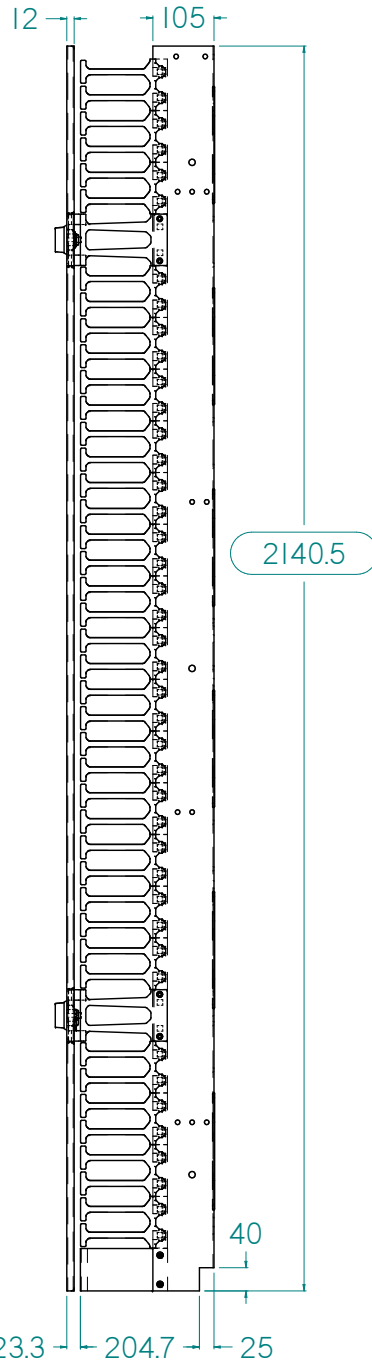

RH SIDE VIEW

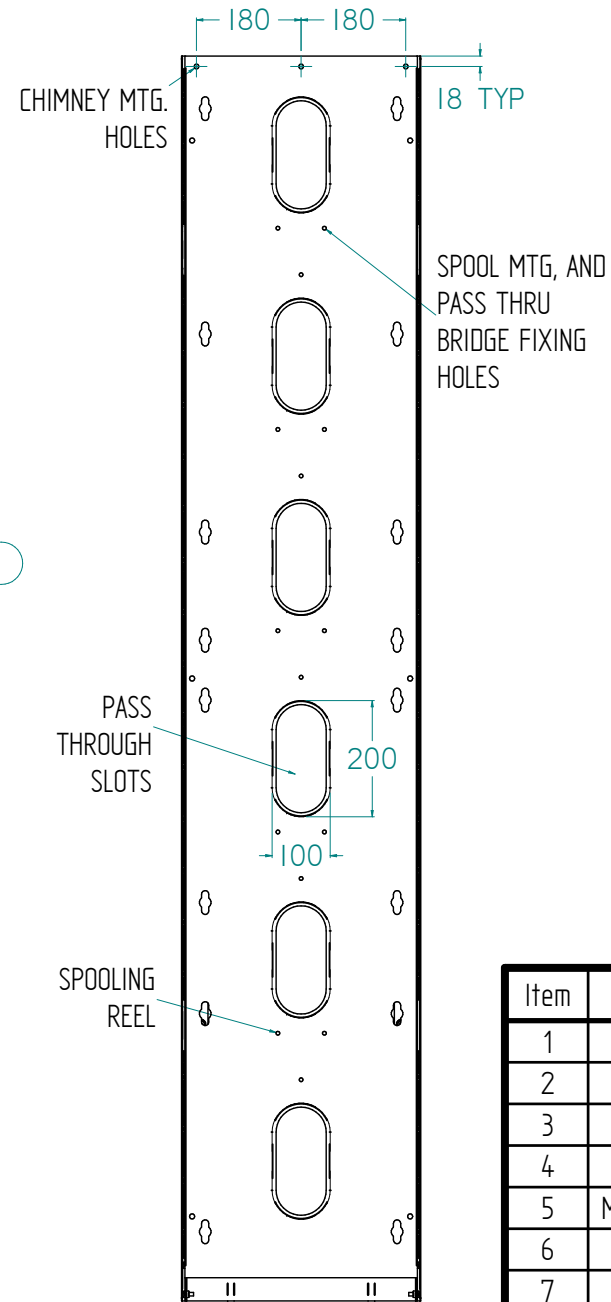

REAR VIEW

REV.	REVISION HISTORY	DATE
0	FIRST PRODUCTION RELEASE	21/11/2014
1	EDGE PROTECTION RUBBER ADDED & HINGE PLATE ADDED	28/05/2015
2	PDU KEYHOLES ADDED TO ITEM 3 CHANNEL	11/02/2019

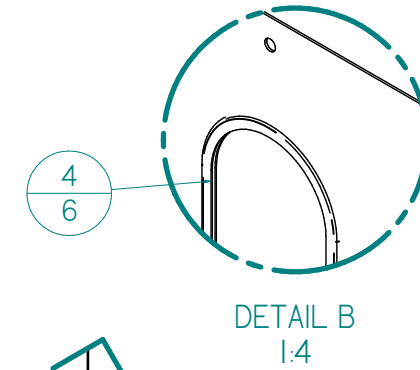

DETAIL B  
1:4

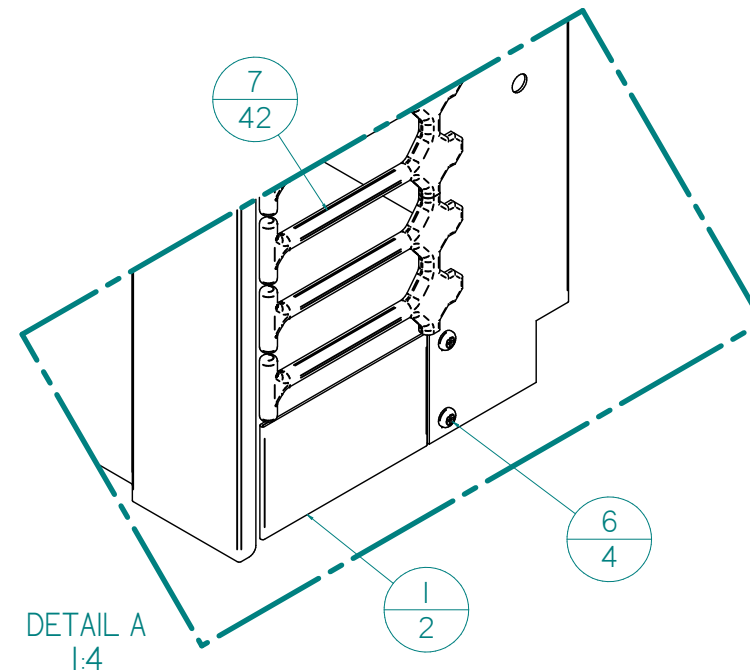

DETAIL A  
1:4

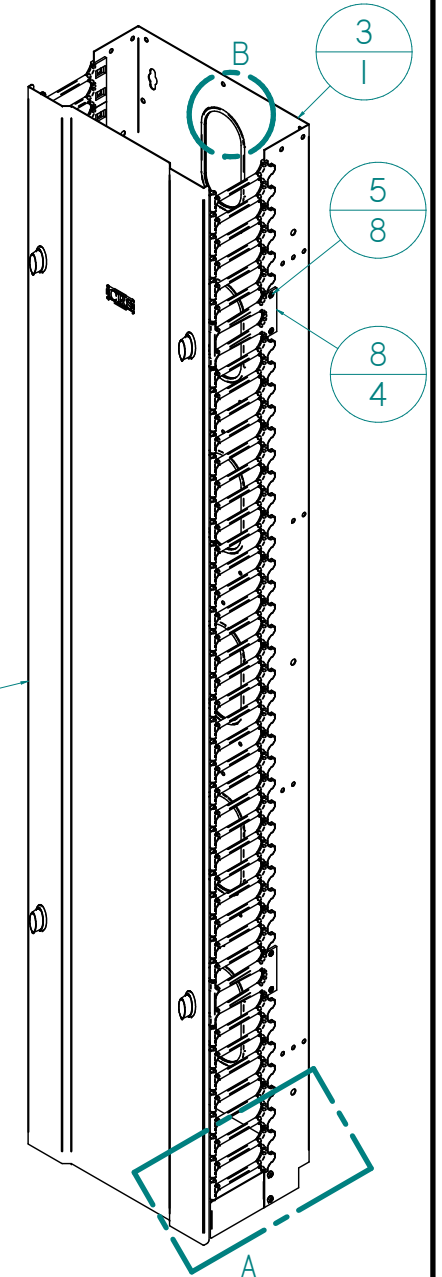

PICTORIAL VIEW  
NTS

Item	Document No.	Rev.	Title	Material	Qty.
1	CRS-2648	0	LOWER DUCT BLANKING PLATE		2
2	CRS-5914	1	COVER 45RU 400 WIDE FOR VERTICAL		1
3	CRS-5915	1	CHANNEL 45RU 400 WIDE FOR VCM	15 M.S	1
4	CRS-6351	0	EDGE PROTECTION RUBBER	PVC	6
5	M6 X 10 SOCKET HD	----	M6 X 10 SOCKET HD C/SUNK SCREW	MS-ZP	8
6	M6 X 12 PAN POZI		M6 X 12 PAN POZI ZP	Aluminum,	4
7	SYC-001	3	SYCOP 2RU LONG FINGER CABLE	ABS Plastic	42
8	SYC-003-SUPPLIED	0	ZINC HINGE DUCT	Zinc	4



FLAT PATTERN DISCLAIMER

AS INDIVIDUAL MANUFACTURERS TOOLING MAY VARY WIDELY IT IS THE MANUFACTURERS RESPONSIBILITY TO DETERMINE CORRECT FLAT SIZES OR WHETHER THE SUPPLIED FLAT DIMENSIONS ARE ACCURATE

DRAWN BY:	INITIAL	TOLERANCES TOLERANCES SET BY NUMBER OF DECIMAL PLACES. ie: 1 decimal - 0.0 = +/- 0.5mm 2 decimals - 0.00 = +/- 0.15mm ANGLES +/- 0.5 deg. ○ DENOTES CRITICAL DIMENSION	MATERIAL	FINISH
	SEE BOM		SEE PO FOR COLOUR	
CHECKED BY:	INITIAL	PROJECT	A3	
SHEET 1 OF 1		DRAWING NO.	FILENAME:	
AS 1100		CRS-5913	CRS-5913_EXTN00400LGFNGRDCNVCWR-ASSY.dwg	
TITLE			REV.	DATE
VERTICAL CABLE MANAGER 45RU 400 WIDE WITH COVER & EXTENDED FINGERS ASSY			2	11/02/2019

ALL DIMENSIONS EXTERNAL UNLESS NOTED OTHERWISE